

Adjustable Electronic Load for Low Voltage DC Applications

*Operates down to 2.5V

by Bill Andreycak and John Wiggenhorn

Testing power supply regulation over a specified output current range is greatly simplified with the use of an adjustable electronic load. Load current can be varied from zero to the full rated value with the twist of a panel mounted potentiometer or by a digital interface. This design note will feature the design of a self biased, constant current adjustable electronic load which is fully operational with input voltages down to 2.5V.

Most electronic loads rely on the available load voltage to power the control and drive circuits. Since a majority of supplies have output voltages of 5 volts, or more, it has been relatively simple to obtain integrated control circuits which operate at those levels. But the emerging trend towards lower supply volt-

ages, for example 3.3V, 3.0V, 2.7V and even 2.5V logic ICs has eliminated many popular control ICs and techniques from consideration. The UC39432 Precision Analog Controller is fully operational from a supply voltage as low as 2.2V and is usable for this electronic load application, in addition to numerous others. This IC features a precision 1.3V reference voltage, a general purpose operational amplifier and a 100mA open collector NPN transistor. Although primarily intended for optocoupler driving in a feedback loop, the UC39432 is a programmable transconductance amplifier and is adaptable to fulfill many low voltage control requirements. Additional information can be obtained from the device's datasheet

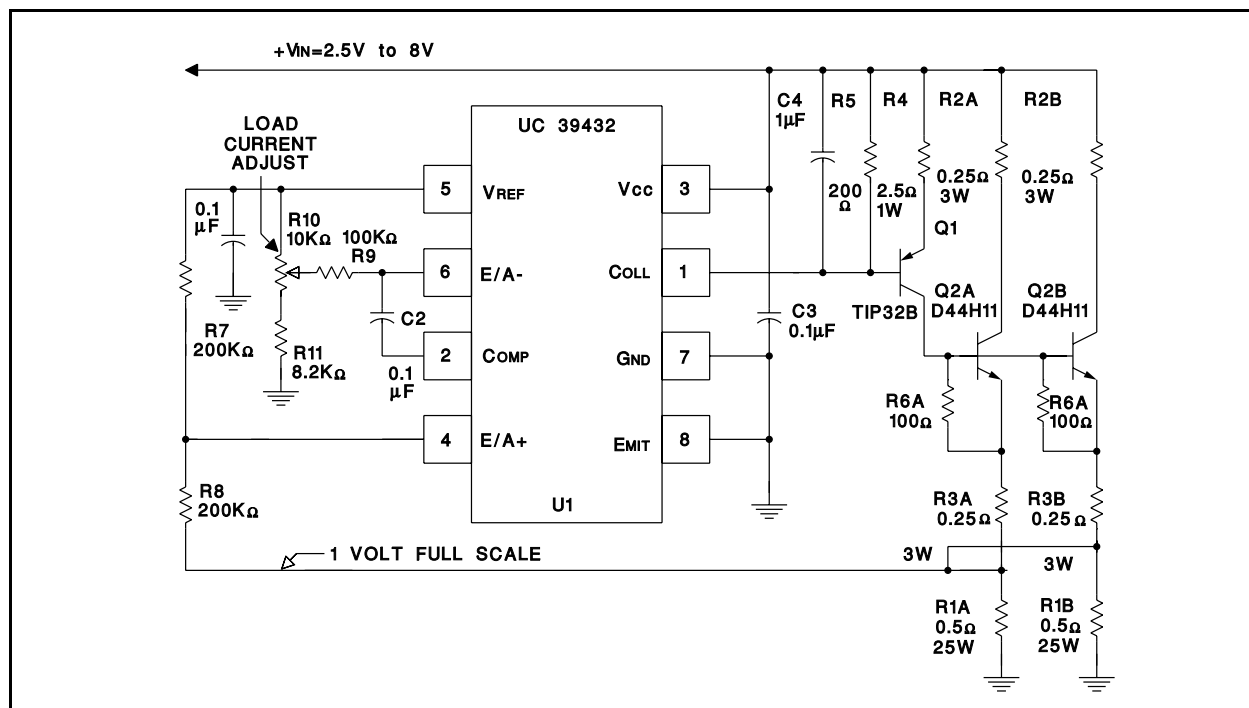

Figure 1. Electronic Load Circuit Schematic

Electronic Load Circuit Operation:

The UC39432 error amplifier noninverting input (pin 4) senses the voltage developed across the paralleled current sense resistors, R1A and R1B. This amplitude is level shifted up by two resistors (R7 and R8) to the ICs reference voltage to maintain the input within its useable common mode range. The inverting input (pin 6) of the amplifier is connected to the wiper of the current adjust potentiometer which programs load current. A 100k ohm series resistor (R9) balances the input impedances while the 8.2k ohm resistor (R11) provides offset to the potentiometer for better resolution. Compensation uses a 0.1 μ F capacitor (C2) which turns the amplifier into an integrator for good DC load stability. Both the input supply voltage to the IC (pin 3) and the 1.3V reference (pin 5) are bypassed with 0.1 μ F capacitors (C4 and C1) for noise rejection.

The power stage of this load consists of a PNP driver (Q1) to the NPN power transistors (Q2A and Q2B) in a Darlington configuration. Very common D44H11 (10A/80V) TO-220 type NPN transistors are conservatively utilized. They provide plenty of flexibility for higher output voltages and higher current applications. Heatsinking incorporates two AAVID Engineering type #E5301 parts and number #150 spring clips for the TO-220 devices. Specifications indicate a 65 degree C rise for 10 Watts of

power dissipation without forced air. This is worst case operation for each transistor with an 8V input and 4A load current. Emitter ballast resistors (R3A and R3B) are included to balance the load current evenly between the NPN transistors. These two devices are held off by 100 ohm base to emitter resistors (R6A and R6B). Series collector resistance (R2A and R2B) is used to further reduce the transistor power dissipation while still enabling 2.5V operation at full load. Base drive for both is provided by a TIP32B (3A/80V) PNP transistor (Q1). Emitter resistance (R4) is used to reduce the system gain and R5 holds Q1 off with no base drive. A 1 μ F capacitor (C4) between the input supply and the base increases stability and reduces the potential for a load surge at power-up.

This general purpose, constant current electronic load can be easily modified for higher current and higher voltage applications with few changes. Additional NPN transistor and heatsink stages can be paralleled to draw higher currents and to divide the heat evenly amongst more transistors. The only other change needed is to the current sense resistor value which should be scaled to develop 1 volt at full current. Low voltage operation may also warrant reducing the value of R4 to provide more base drive with the same voltage drop.